



# DUAL PISTON HYDRAULIC PUMPS

**SERVICE MANUAL**  
**(Hi-Lo Two Speed, Hand or Foot Operated)**



**STAR HYDRAULICS, LLC**  
2727 CLINTON STREET  
RIVER GROVE, ILLINOIS 60171  
708/453/3238  
[www.starhyd@starhyd.com](http://www.starhyd@starhyd.com)

**MAINTENANCE**

In servicing hydraulic units, cleanliness is of the utmost importance. A clean work place and proper tools are necessary to insure efficient and effective repair. Special tools can be furnished on request.

**NOTE:** Please specify pump model number when ordering parts. If you are not sure of your pump model number, call the factory and request a pump model identification sheet be faxed or e-mailed to your. Pump parts lists are also available for your model.

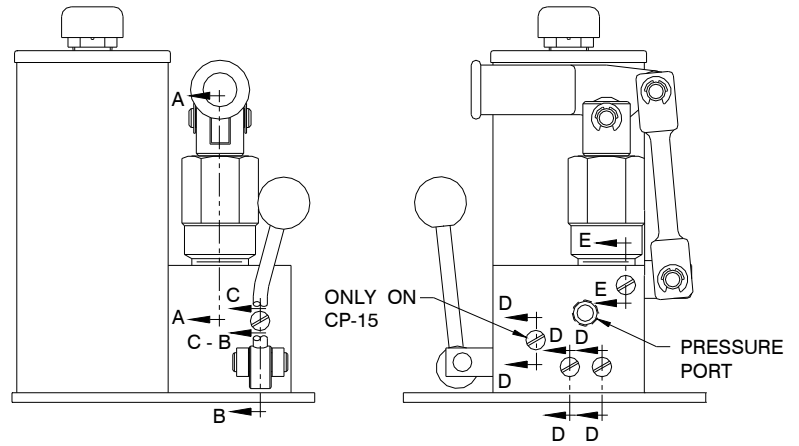

Typical assembly drawing of two speed pump showing sectional view location.

TROUBLE	POSSIBLE CAUSE	CORRECTIVE REPAIR INSTRUCTIONS
Pump will not hold pressure	<ol style="list-style-type: none"> <li>1. Release valve ball not seating properly</li> <li>2. Ball valves not seating properly</li> <li>3. Overload valve ball not seating properly</li> <li>4. Large piston unloading valve seal faulty</li> </ol>	<p>Refer to "Release Valve" notes</p> <p>Refer to "Pump Valve" notes</p> <p>Refer to "Overload Valve" notes</p> <p>Refer to "Large piston unloading valve"</p>
Pump fails to supply pressure	<ol style="list-style-type: none"> <li>1. Lack of oil</li> <li>2. Air bound pump</li> <li>3. Release valve ball not seating properly</li> <li>4. Small ball in valve circuit not seating properly</li> <li>5. Overload valve ball not seating properly</li> <li>6. Large piston unloading valve seal faulty</li> </ol>	<p>Refer to "Oil" notes</p> <p>Refer to "Air Bleeding" notes</p> <p>Refer to "Release Valve" notes</p> <p>Refer to "Pump Valve" notes</p> <p>Refer to "Overload Valve" notes</p> <p>Refer to "Large piston unloading valve"</p>
Pump piston does not draw a full charge. (This is evident by a cushion effect at the top of the pump stroke)	<ol style="list-style-type: none"> <li>1. Air bound system</li> <li>2. Lack of oil</li> </ol>	<p>Refer to "Air Bleeding" notes</p> <p>Refer to "Oil" notes</p>
Pump piston raises by itself under pressure	Large ball in ball valve circuit not seating properly	Refer to "Pump Valve" notes
Pump functions properly but will generate only a given pressure below its normal pressure maximum	Overload valve not properly set	Refer to "Overload Valve" notes
Pump fails to supply greater output at no load than under load.	Large piston unloading valve not set properly	Refer to "Large piston unloading valve"

**Air Bleeding**

Air accumulation in a hydraulic system will cause erratic action. This may appear as pump failure to the inexperienced user. For this reason, it is advisable to air bleed each pump before attempting to operate. To remove air from the pump, open release valve with the pump in an upright position. Operate the pump slowly through the full piston stroke about a dozen times. Close the release valve. Pump should be ready for use.

## Oil

If the pump fails to operate, check the oil level before attempting any repairs.

The maximum fill level is 1 1/2" below the inside of the reservoir cover.

CAUTION: Use only hydraulic oil when refilling. NEVER USE BRAKE FLUID.

## Pump Piston

Leakage of oil around the pump piston may indicate worn or damaged piston packings.

To replace packings:

- a) Remove the piston actuating linkage
- b) Remove the piston. (See piston section drawing A-A)
- c) Remove all packings. (see piston section drawing A-A)
- d) Clean all parts and dry with compressed air.
- e) Install new packings, wipers, and static seals making sure that packing seal lips are face down toward the pressure. (Lubricate each part into clean hydraulic oil before assembly)
- f) Open the release valve (to allow air to bleed from the piston barrel back to the reservoir) and insert the piston.
- g) Replace piston linkage.
- h) NOTE: With release valve open, stroke pump about a dozen times to bleed air completely from the pump.

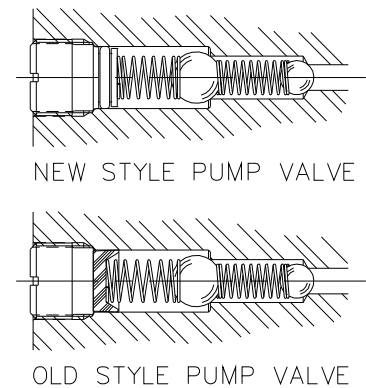
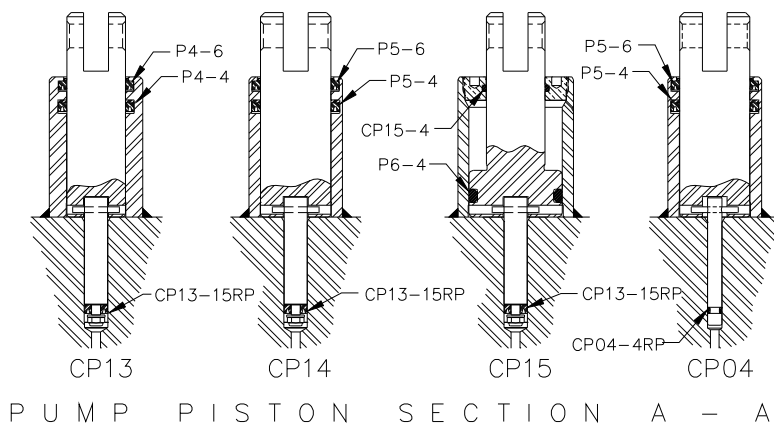

SECTION D-D

## Pump Valves

If the pump fails to supply pressure or if the pump piston is under pressure at all times, the pump valves may need cleaning. Stand pump in an upright position. Remove the valve plug and seal. Tilt the pump to remove valve springs and balls. Allow oil to drain from the reservoir through these valve holes to wash foreign matter from the valve cavity. Lay pump on its side to clean and inspect valve chamber. Be careful not to mar or nick the ball valve seats. Clean the valve balls and springs in solvent. Replace rusted or corroded balls. Do not stretch the ball springs. To reassemble, insert in sequence, the small ball, small spring, large ball, and large spring into the cleaned chamber. Finally, screw in valve seal plug. Note that the seal kit contains the new style valve plug and seal. This procedure should be carried out in all ball valve circuits. If the valves fail to operate properly after they have been cleaned, it may be necessary to reseat the valve balls. Remove the springs and tap each ball lightly in its respective seat using the 1/4" ball seating tool (CP13-42) for the small ball and the 3/8" ball seating tool (CP13-43) for the large ball. Remove balls to make sure they are not stuck to the seats. Reassemble pump valves as before. See "Air Bleeding" instructions before attempting to operate the pump.

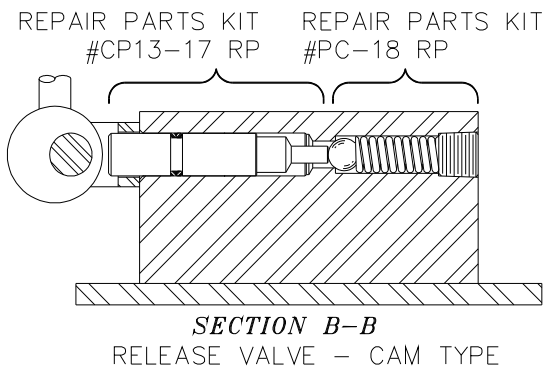

## Release Valve - Cam Type

If the pump fails to lift or hold a load, the release valve may be dirty. From back of pump remove the release valve plug, release ball spring and 3/8" release ball. From the front, remove the release lever pin, release lever and release plunger and seal. Clean release valve chamber and inspect the ball seat. If necessary, re-seat the release ball by tapping it lightly on the ball seat, using the 3/8" ball seating tool (CP13-43). Clean plunger and inspect the plunger packing and replace if necessary. To reassemble, insert the ball, ball spring, and release valve plug. Lubricate the release plunger packing with hydraulic oil and carefully insert into the plunger chamber. Re-install the release lever and lever pin. See "Air Bleeding" instructions before attempting to operate the pump.

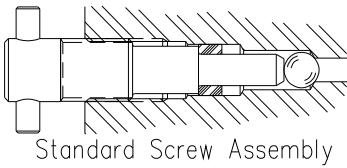

Standard Screw Assembly

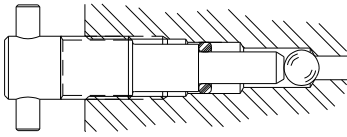

EPR/Viton Screw Assembly

**SECTION B-B**  
SCREW RELEASE VALVE  
KIT No. P1-3 RP

- CP13-13 RP FOR P1A MODELS
- P3A-13 RP FOR P2A, P3A, P4A MODELS
- P5A-13 RP FOR P5A MODELS
- P6A-13 RP FOR P6A MODELS

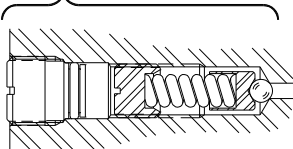

New Style Overload Valve Ass'y.

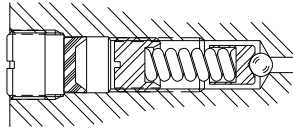

Old Style Overload Valve Ass'y.

**SECTION C-C**  
OVERLOAD VALVE

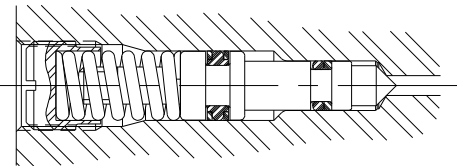

**SECTION E-E**  
LARGE PISTON RELIEF VALVE

**Release Valve – Screw Type**

If the pump fails to lift or hold a load, the release valve may be dirty. Remove the release screw, release valve seal and 9/32" release valve ball. Clean and inspect valve seat and screw. A slight depression in the end of the screw is not harmful. Screws with excessive deformation should be replaced. Re-seat the release ball using the 1/4" ball seating tool (CP13-42). To reassemble, insert the release valve packing using inserting tool P1A-40. Reinstall the release screw. See "Air Bleeding" instructions before attempting to operate the pump.

**Overload Valve**

If the pump fails to lift or hold a load after the release valve and pump valves have been checked, the overload valve may be dirty. To clean the valve, remove valve plug and valve plug seal. Using a screwdriver, remove the overload valve screw, valve spring, valve plunger and steel ball. Clean and inspect valve cavity. If the ball seat is marred, re-seat the overload ball by lightly tapping the ball on seat using tool (CP13-45). Remove the ball to prevent sticking. Reassemble the ball, plunger, spring and valve screw. Connect a pressure gage to the pressure outlet. Stroke the pump to obtain maximum desired pressure. Turn the valve screw clockwise to increase the pressure reading and counter-clockwise to reduce the maximum reading. After valve is set properly, replace valve plug. Note that the seal kit contains the new style valve plug and seal. See "Air Bleeding" instructions before attempting to operate the pump.

**Large Piston Pump Relief Valve**

If the pump fails to lift faster under no load than it does under heavy load, the large piston unloading valve may be dirty. This valve is covered with a sealing compound to prevent tampering. Remove the sealing compound, valve screw, spring and plunger with seals. Use threaded socket tool (CP13-41) to remove plunger. Clean and inspect the valve cavity. Inspect the plunger packings and replace if necessary. To reassemble, lubricate the plunger seals with hydraulic fluid and carefully insert it back into the valve cavity taking care not to damage the seals. Reassemble the spring and valve screw. Tighten the screw to obtain the desired effort on lever bar at large piston change-over point. If the screw is tightened too far it will restrict the unloading valve movement and cause excessive handle effort throughout the high pressure cycle.

*SPECIAL TOOLS AVAILABLE FOR REPAIRING STAR PUMPS ARE SHOWN BELOW*

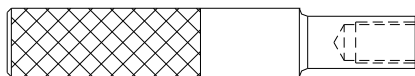

UNLOADING VALVE TOOL  
(PART No. CP13-41)

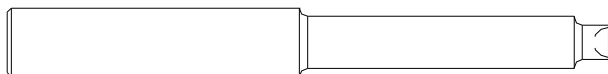

OVERLOAD VALVE BALL SEATING  
TOOL (PART No. CP13-45)

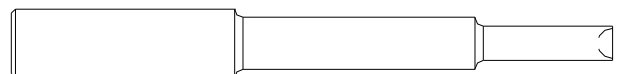

1/4" BALL SEATING TOOL  
(PART No. CP13-42)

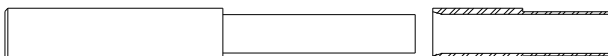

INSERTING TOOL FOR P1A-4 RELEASE  
VALVE SEAL (PART No. P1A-40)



3/8" BALL SEATING TOOL  
(PART No. CP13-43)