

# SP SERIES

## STAR Single Piston Pumps

1/2" - 3/4" - 1" Diameters

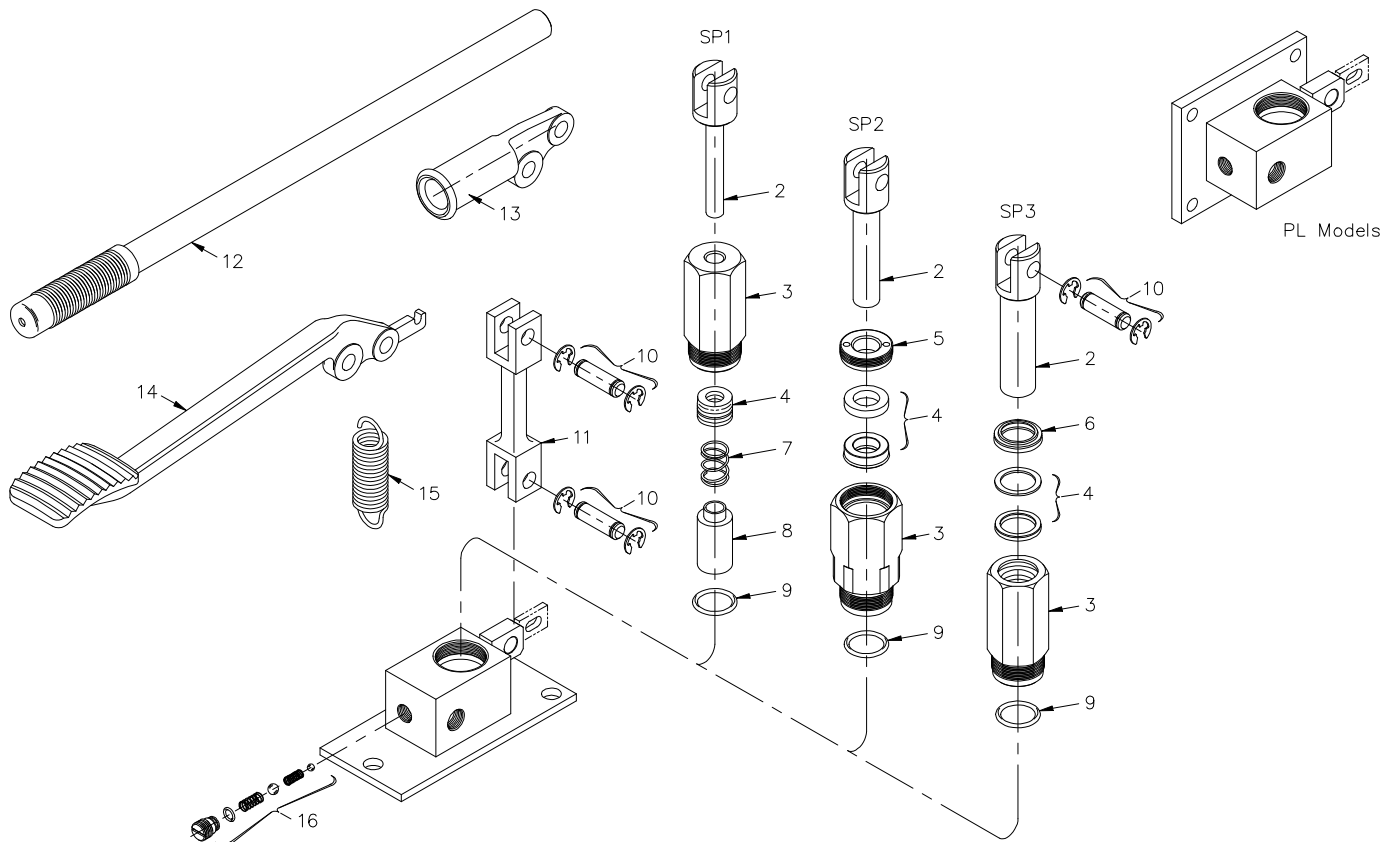

These models can be:

- Hand or foot operated
- Without reservoir
- Base or flange mounted

Please give the following information when ordering parts:

- Part Number
- Part Name
- Model No. of Pump

ITEM	PART NAME	1/2" Piston	3/4" Piston	1" Piston
		PART NO.	PART NO.	PART NO.
	Repair Kit (Includes items marked *)	SP1A-RK	SP2A-RK	SP3A-RK
2	Pump Piston	P1-7	P2-4	P3-2
3	Pump Barrel	P1-6	P2-2	P3-3
4	Pump Piston Packing	* P1-17	* P2-5RP	* P3-4RP
5	Pump Packing Nut	---	P2-3	---
6	Pump Piston Wiper	---	---	* P3-6
7	Pump Packing Spring	P1-18	---	---
8	Pump Piston Sleeve	P1-19	---	---
9	Pump Barrel Seal	* P1-20	* P1-20	* P1-20
10	Piston / Link Pin (Includes Rings) (3 Required)...	CP13-10RP	CP13-10RP	CP13-10RP
11	Pump Link	CP13-12	CP13-12	CP13-12
12	Hand Pump Lever	CP13-23	CP13-23	CP13-23
13	Hand Pump Lever Socket	CP13-9	CP13-9	CP13-9
14	Foot Pump Lever	FCP12-9	FCP12-9	FCP12-9
15	Foot Pump Lever Return Spring	FCP13-23	FCP13-23	FCP13-23
16	Pump Valve (Complete)	* P1-12RP	* P1-12RP	* P1-12RP